



Tailoring your Volvo FH.

No single truck fits all. That's why the Volvo FH series provides endless possibilities. The flexible chassis layout and clear advice from the VBI Volvo Bodybuilder Instructions make it easy to prepare the truck for a superstructure. While the driveline, cabs and equipment packages provide you with even more options. So welcome to a world of choices. A world where your dealer will happily guide you in finding the perfect truck for your needs and wants.

1

CHASSIS

Truck models, chassis heights, wheelbases, bogies, rear suspensions and brakes.

PAGES 35-38

2

DRIVELINE

Engines, gearboxes, I-Shift software, rear axles, rear axle ratios and power take-offs.

PAGES 38-43

3

CAB

Specifications and measurements for the sleeper, Globetrotter and Globetrotter XL cabs.

PAGES 44-46

4

EQUIPMENT PACKAGES

Complete equipment packages for improved driver's comfort, safety and operating economy.

PAGES 47-49

5

ACCESSORIES

There are plenty of ways you can accessorise your Volvo FH. View some of the highlights.

PAGES 50-51



DRIVE / CHASSIS HEIGHT / WHEELBASE (dimensions in m)

Tractor 4x2

Rear Air	Standard	3.5	3.6	3.7	3.8
	Medium	3.5	3.6	3.7	3.8
	Low	3.5	3.6	3.7	3.8
	X-Low	3.5	3.6	3.7	3.8

Tractor 6x2

Tag	Standard	3.0	3.2						4.9
	Medium	3.0	3.2						4.9
Pusher	Standard					3.9	4.1		4.9
	Medium					3.9	4.1		4.9

Tractor 6x4

B ride	Standard	3.0	3.2			
T ride1	Standard	3.0	3.2	3.4	3.6	3.9
T ride2	Standard	3.0	3.2	3.4	3.6	3.9
Rear Air	Standard	3.0	3.2	3.4		

Tractor 8x4

Pusher Tridem	Standard					3.9
---------------	----------	--	--	--	--	-----

DRIVE / CHASSIS HEIGHT / WHEELBASE (dimensions in m)

Rigid 4x2

Rear Air	Standard	3.4	3.7	4.0	4.3	4.6	4.9	5.2	5.6	6.0	6.3	6.5	6.7
	Medium		3.7	4.0	4.3	4.6	4.9	5.2	5.6	6.0	6.3	6.5	6.7
	Low						4.9	5.2	5.6	6.0	6.3	6.5	6.7

Rigid 6x2

Tag	Standard	3.5	3.7	3.9	4.3	4.6	4.8	4.9	5.2	5.6	6.0
	Medium	3.5	3.7	3.9	4.3	4.6	4.8	4.9	5.2	5.6	6.0
	Low	3.5	3.7	3.9	4.3	4.6	4.8	4.9	5.2	5.6	6.0

Rigid 6x4

B ride	Standard		3.7	3.9	4.3	4.6	4.9	5.2	5.6
T ride1	Standard		3.7	3.9	4.3	4.6	4.9	5.2	5.6
T ride2	Standard		3.7	3.9	4.3	4.6	4.9		5.6
Rear Air	Standard		3.7	3.9	4.3	4.6	4.9	5.2	5.6
	Medium		3.7	3.9	4.3	4.6	4.9	5.2	5.6
	Low		3.7	3.9	4.3	4.6	4.9	5.2	5.6

Rigid 8x2

Rear Air	Standard								5.1	5.6	6.0
----------	----------	--	--	--	--	--	--	--	-----	-----	-----

Rigid 8x4

B ride	Standard								5.1	5.6	6.4	
T ride1	Standard								5.1	5.6		
T ride2	Standard								5.1	5.6	6.0	6.2
Rear Air	Standard				4.3	4.6	4.9	5.1		5.6	6.0	6.4
Tag Tridem	Standard	3.2	3.4	3.7	3.9	4.1	4.3	4.6	4.9	5.1	5.2	
	Medium			3.7	3.9	4.1	4.3	4.6	4.9	5.2		
Pusher Tridem	Standard					4.3	4.6	4.9	5.1	5.3	5.6	
	Medium					4.3	4.6	4.9	5.1	5.3	5.6	

1 CHASSIS

CHASSIS LAYOUT FEATURES

The chassis is developed to give optimum space for superstructure and equipment. Here are some of the key features, which may vary depending on the truck's specification.

TRACTOR

BATTERY BOX (BBOX-L)

Moved forward 300 mm compared with previous design. On tractors this offers 100–120 litres more fuel capacity.

BATTERY BOX (BBOX-EF)

Placed in the rear between the chassis frames is an option on tractors.

ADBLUE TANK

On tractors the AdBlue tank can be mounted on top of frame, behind the cab, offering more fuel capacity (ADTP-BC).

APM

Air Production Modulator on tractors is placed between the chassis rails to create more space for chassis-mounted equipment such as fuel tanks.

RIGID

FREE FRAME SPACE

The chassis packaging can be moved rearwards to give space for crane legs or other equipment. (FAA10; 500 mm), (FAA20; 600 mm).

FRAME BODY BUILDER HOLE ROW

The upper hole row is reserved for the body builder. All brackets in upper hole row have an offset and an 8mm spacer. No rivets are used in the upper hole row.

CRANE PREPARATION

Crane plates on the chassis can be factory mounted.

REAR AIR SUSPENSION AND SHORT REAR END

The rear overhang can be shorter thanks to a redesigned forward-mounted stabiliser bar. This is a benefit for construction applications and improves the asphalt-layer interface and swapbody applications.

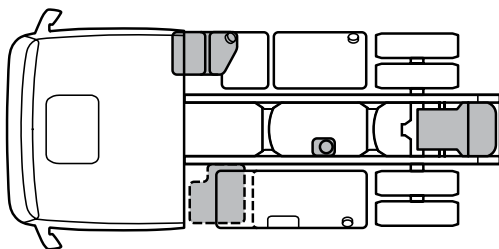

TRACTOR

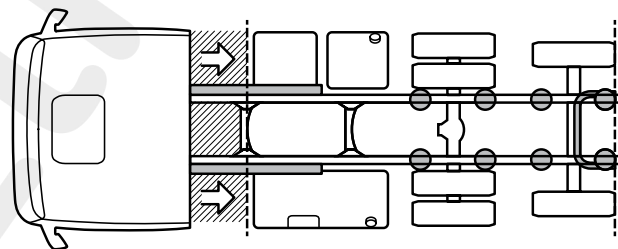

RIGID

CHASSIS HEIGHTS

X-Low (Tractors only)	approximately 810 mm
Low	approximately 850 mm
Medium	approximately 900 mm
Standard	approximately 1000 mm

TOWBARS

Centrally mounted, semi-undermounted and undermounted towbar for trailer with centre axle. Towbars can be fitted at intervals of 25 mm.

FUEL TANKS

Aluminium or steel tanks in volumes from 150 to 900 litres. Maximum fuel volume is 1480 litres for a 4x2 tractor.

ADBLUE TANKS

Volumes from 32 to 90 litres. AdBlue pump is integrated in AdBlue tank module. Plastic.

FIFTH WHEELS

Certified installation permits up to 36 tonnes load. An ISO fifth wheel with L-shaped profiles at different heights is included in the range, offering considerable freedom of choice. A flange-mounted fifth wheel is a low-weight variant since it does not require any attachment plate. There are a range of fifth wheel heights to meet operator demands. Integrated lubrication and in cab trailer connection indicator is available as an option for specific variants.

TAG AXLES

Available in several configurations – fixed with single or dual wheels, self steered or actively steered. Axle load: 7.5 tonnes.

PUSHER AXLES

Available as a fixed or actively steered option on 6x2 push axle tractors and tridem rigid. Axle load: 7.5 tonnes.

MAX FRONT AXLE LOAD (tonnes)

	Air	Leaf
X-Low	8	-
Low	8	-
Medium	9	9
Standard	9	10



REAR SUSPENSION

Type	Axle combination	Suspension type	Axle/bogie load (tonnes)	Reduction	Third or Fourth axle
Solo					
<input type="checkbox"/> RAD-GR	4x2	Air	11.5/13	Single/hub	
Bogie					
<input type="checkbox"/> RADT-GR	6x2/8x2	Air	19/20.5/22.5/23	Single/hub	Fixed/steered tag axle/selfs/prop
<input type="checkbox"/> RAPD-GR	6x2	Air	19/22	Single/hub	Fixed/steered pusher axle
<input type="checkbox"/> RADD-BR	6x4/8x4	Parabolic	21	Single/hub	
<input type="checkbox"/> RADD-TR1	6x4/8x4	Parabolic/conventional leaf	23/26	Single/hub	
<input type="checkbox"/> RADD-TR2	6x4/8x4	Conventional leaf	26/32	Hub	
<input type="checkbox"/> RADD-GR	6x4/8x4	Air	21/23/26	Single/hub	
<input type="checkbox"/> RADDT-GR	8x4	Air	27.5/33/36	Single/hub	3 axles/steered tag axle
<input type="checkbox"/> RAPDD-GR	8x4	Air	27.5/32/35	Single/hub	3 axles/steered pusher axle

FIFTH WHEEL COUPLING HEIGHTS

Drive	Chassis height	Suspension	Frame height	Fifth wheel height*	Tyre Size	Min. coupling height**	Nominal drive height**
4x2	X-Low	RAD-GR	266	140	295-55	867	912
	X-Low	RAD-GR	266	140	295-60	887	932
	Low	RAD-GR	266	140	315-60	955	1015
	Medium	RAD-GR	266	140	315-70	1014	1075
	Medium	RAD-GR	300	140	315-70	1031	1092
	Standard	RAD-GR	266	140	315-80	1056	1147
	Standard	RAD-GR	300	140	315-80	1090	1164
6x2	Low	RADT-GR	266	160	315-60	975	1035
	Medium	RADT-GR	266	160	315-70	1034	1095
	Medium	RADT-GR	300	160	315-70	1051	1112
	Standard	RADT-GR	300	150*	315-80	1160	1234
	Medium	RAPD-GR	266	160	315-70	1034	1095
	Medium	RADT-GR	300	160	315-70	1051	1112
	Standard	RAPD-GR	266	160	315-80	1076	1167
6x4	Standard	RAPD-GR	300	160	315-80	1110	1184
	Standard	RADD-GR	300	150*	315-80	1173	1234

* +60 mm mounting height. ** Approx. heights.



1 CHASSIS

BRAKES

Volvo EBS (Electronically controlled Brake System) disc brakes are available with program packages for rigids and tractors. ESP is available for tractors and rigids with 4x2, 6x2 and 6x4 drive. In this way Volvo can offer ESP on virtually all ADR applications and EMS combinations. The brake range also includes Volvo Z-cam drum brakes with ABS (Anti-lock Braking System) on heavy duty construction and heavy haulage models.

EBS MEDIUM

In addition to the features of the EBS Standard package, see below. **+**

EBS STATUS CONTROL

EBS status monitoring via the TEA2+ vehicle electronic system and VCADS Pro.

HILL START AID

The service brakes support the park brake during a hill start. The service brake are only released once there is sufficient engine torque to drive the vehicle forward.

LINING WEAR ANALYSIS

Brake lining warning - calculates the remaining mileage available with the current brake linings.

AUTOMATIC PARKING BRAKE RELEASE

The parking brake is automatically released when the driver presses the accelerator pedal when a gear has been selected to drive away. It does not work in neutral, only available with I-shift gearbox.

PARKING BRAKE ACTIVATOR ON TRAILER

There is an optional parking brake that activates automatically also on the trailer, ideal for heavy haulage applications.

ADDITIONAL OPTIONS

In addition to the programme packages there are the following options:

STRETCH BRAKE

Enables the driver to request pulse braking of the trailer. The brake is then automatically activated and the risk of jack-knifing is minimised. Only for Rigid.

ESP (ELECTRONIC STABILITY PROGRAM)

The electronic brake stability system applies the brakes individually on each wheel, thereby providing stability for the entire vehicle combination to counteract jack-knifing, rollover and trailer swing. ESP fulfils the legislation of Electronic Vehicle Stability Control. **+**

EMERGENCY BRAKE LIGHT

When panic braking from speed above 50 km/h, the brake lights flash with four flashes per second. **+**

HYDRAULIC RETARDER

Gearbox-mounted compact retarder with a max effect of 440 kW.

2 DRIVELINE

DRIVELINE COMBINATIONS

Manual gearbox	D13C420	D13C460	D13C500	D13C540	D13K460	D16G540	D16G600	D16G700	D16G750
VT2214B	•								
VT02214B	•								
VT2514B	•	•	•						
VT02514B	•	•	•						
VT2814B				•		•	•		
VT02814B				•		•	•		

I-Shift

AT2412D	•	•							
AT2612D	•	•	•	•	•				
ATO2612D	•	•	•	•					
AT2812D						•	•		
ATO3112D						•	•	•	
ATO3512D									•

Single reduction axles

RSS1344C	•	•	•	•	•				
RSS1356	•	•	•	•	•	•	•		
RSS1360	•	•	•	•	•	•	•	•	•
RTS2370A	•	•	•	•	•	•	•	•	•

Hub reduction axles

RSH1370F	•	•	•	•	•	•	•	•	•
RT2610F	•	•	•	•	•	•	•	•	•
RT3210F	•	•	•	•	•	•	•	•	•
RTH3312	•	•	•	•	•	•	•	•	•

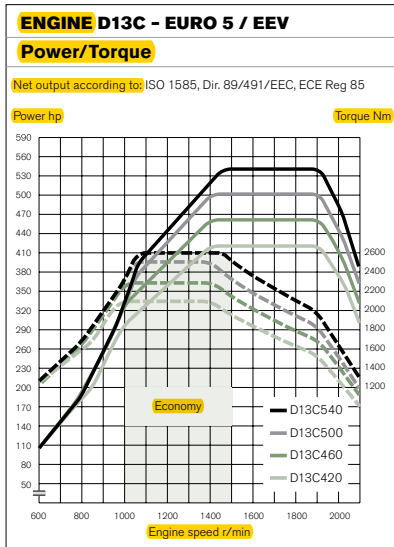

<input type="checkbox"/> D13C420 (309 kW)	
Max power at 1400–1900 r/min	420 hp
Max torque at 1000–1400 r/min	2100 Nm
<input type="checkbox"/> D13C460 (338 kW)	
Max power at 1400–1900 r/min	460 hp
Max torque at 1000–1400 r/min	2300 Nm
<input type="checkbox"/> D13C500 (368 kW)	
Max power at 1400–1900 r/min	500 hp
Max torque at 1050–1400 r/min	2500 Nm
<input type="checkbox"/> D13C540 (397 kW)	
Max power at 1450–1900 r/min	540 hp
Max torque at 1050–1450 r/min	2600 Nm

D13C

No. of cylinders	6
Displacement	12.8 litres
Stroke	158 mm
Bore	131 mm
Compression ratio	17.8:1
Economy revs	1000–1500 r/min
Exhaust braking effect (2300 r/min)	185 kW
VEB effect (2300 r/min)	300 kW
VEB	option on the D13C420
VEB+ effect (2300 r/min)	375 kW
VEB+	option on all D13C engines
Oil filters	2 full-flow, 1 bypass
Oil change volume, incl. filter	33 litres
Cooling system, total volume	38 litres
Oil change interval: Up to 100,000 km, or once a year with VDS4.	

EMISSION LEVEL EEV
Available for all D13C engines, except D13C540. **+**

ENGINE-MOUNTED POWER TAKE-OFF **+**

Two torque output versions available*:

EPTT650, ratio 1.26:1	650 Nm
EPTT1000, ratio 1.26:1	1000 Nm

* Torque output both when driving and standing still.

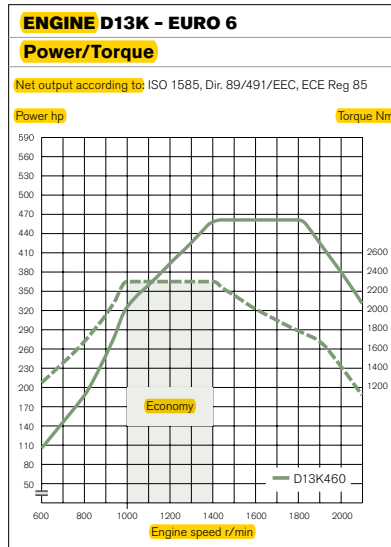

<input type="checkbox"/> D13K460 (338 kW)	
Max power at 1400–1800 r/min	460 hp
Max torque at 1000–1400 r/min	2300 Nm

D13K

No. of cylinders	6
Displacement	12.8 litres
Stroke	158 mm
Bore	131 mm
Compression ratio	17.0:1
Economy revs	1000–1400 r/min
Exhaust braking effect (2300 r/min)	185 kW
VEB+ (standard), effect (2300 r/min)	375 kW
Oil filters	2 full-flow, 1 bypass
Oil change volume, incl. filter	33 litres
Cooling system, total volume	38 litres
Oil change interval: Up to 100,000 km, or once a year with VDS4.	

ENGINE-MOUNTED POWER TAKE-OFF **+**

Two torque output versions available*:

EPTT650, ratio 1.26:1	650 Nm
EPTT1000, ratio 1.26:1	1000 Nm

* Torque output both when driving and standing still.

D13K460 MODELS

4x2 tractor and rigid
6x2 pusher tractor
6x2 tag tractor and rigid
GCW up to 60 tonnes
Long haul and distribution assignments.

EURO 6 FUEL PREREQUISITES
ULSD quality (Ultra-low-sulphur diesel, max 10 ppm sulphur).

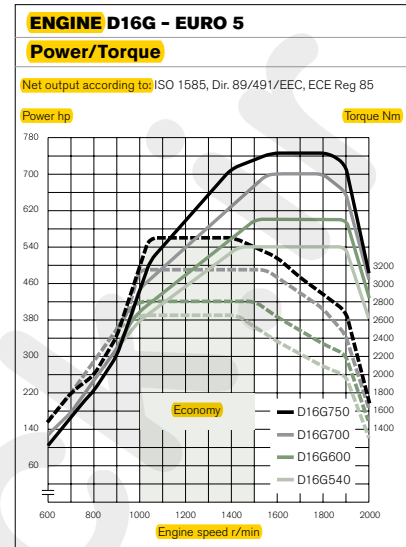

<input type="checkbox"/> D16G540 (397 kW)	
Max power at 1450–1900 r/min	540 hp
Max torque at 1000–1450 r/min	2650 Nm
<input type="checkbox"/> D16G600 (441 kW)	
Max power at 1500–1900 r/min	600 hp
Max torque at 1000–1500 r/min	2800 Nm
<input type="checkbox"/> D16G700 (515 kW)	
Max power at 1550–1800 r/min	700 hp
Max torque at 1000–1550 r/min	3150 Nm
<input type="checkbox"/> D16G750 (551 kW)	
Max power at 1600–1800 r/min	750 hp
Max torque at 1050–1400 r/min	3550 Nm

D16G

No. of cylinders	6
Displacement	16.1 litres
Stroke	165 mm
Bore	144 mm
Compression ratio	16.8:1
Economy revs	1000–1500 r/min
Economy revs D16G750	1000–1400 r/min
Exhaust braking effect (2200 r/min)	230 kW
VEB+ effect (2200 r/min)	425 kW
VEB+	option
Oil filters	2 full-flow, 1 bypass
Oil change volume, incl. filter	42 litres
Cooling system, total volume	48 litres
Oil change interval: Up to 100,000 km, or once a year with VDS4.	

EMISSION LEVEL EEV
Available for D16G750 engine.

ENGINE-MOUNTED POWER TAKE-OFF **+**

Two torque output versions available*:

EPTT650, ratio 1.26:1	650 Nm
EPTT1000, ratio 1.26:1	1000 Nm

* Torque output both when driving and standing still.



2 DRIVELINE

I-SHIFT

12-speed splitter and range gearbox with automated gearchanging system. I-Shift can be factory-fitted or retro-fitted with an oil-cooler, power take-off and compact retarder.

I-SHIFT

Type	Top gear	Engine torque (Nm)	GCW approval (tonnes)
<input type="checkbox"/> AT2412D	Direct	2400	44
<input type="checkbox"/> AT2612D	Direct	2600	60
<input type="checkbox"/> ATO2612D	Overdrive	2600	60
<input type="checkbox"/> AT2812D	Direct	2800	44/52
<input type="checkbox"/> ATO3112D	Overdrive	3150	60
<input type="checkbox"/> ATO3512D	Overdrive	3550	60

I-SHIFT SOFTWARE PACKAGES

BASIC

Supplied as standard with I-Shift and gives the gearbox its basic functions.

DISTRIBUTION & CONSTRUCTION

Tailors the gearbox's work for distribution and construction operations. Features include functions that aid the driver when starting and in close-quarter manoeuvring. +

LONG HAUL & FUEL ECONOMY WITH I-SEE

Adds I-See, including I-Cruise, to the Long Haul & Fuel Economy package, for even greater fuel savings. +

LONG HAUL & FUEL ECONOMY

Contains intelligent functions that minimise fuel consumption. This makes the program package particularly suitable for long-haul operations. +

HEAVY DUTY TRANSPORT

Optimises I-Shift for heavy gross combination weights (>85 tonnes). +

I-SHIFT SOFTWARE PACKAGES

Functions	Basic	Distribution & Construction	Long Haul & Fuel Economy	Long Haul & Fuel Economy with I-See	Heavy Duty Transport*
Basic Shift Strategy	●	●	●	●	●
Performance Shift	●	●	●	●	●
Basic Gear Selection Adjustment	●	●	●	●	●
Gearbox Oil Temperature Monitor	●	●	●	●	●
Enhanced Shift Strategy		●	●	●	●
Launch Control		●	●	●	●
I-Roll			●	●	●
Smart Cruise Control			●	●	●
I-See, including I-Cruise				●	
Heavy Duty GCW Control					●
Additional options					
Enhanced PTO Functions	●	●	●	●	●
Enhanced Gear Selection Adjustment, including Kickdown		●	●	●	●
Enhanced performance – Bad roads		●	●	●	●

* Only AT2612D, ATO3112D and ATO3512D.

**I-SHIFT FUNCTIONS EXPLAINED****BASIC SHIFT STRATEGY**

Automatic selection of the right starting ratio (1st – 6th gear). The choice of starting gear is influenced by gross weight and road gradient.

PERFORMANCE SHIFT

Gives faster and gentler changes through intelligent utilisation of the engine brake, the vehicle's clutch and a special transmission brake.

BASIC GEAR SELECTION ADJUSTMENT

Makes it possible to adjust gear selection via the gear lever's buttons during engine braking in automatic mode.

GEARBOX OIL TEMPERATURE MONITOR

Shows the gearbox oil's temperature in the information display.

ENHANCED SHIFT STRATEGY

By interacting with EBS and ECS, starting and close-quarter manoeuvring are made easier. Maximises the VEB braking effect by automatically selecting the right gear so that the engine operates at higher revs. When changing gear during engine braking, the wheel brakes are activated to compensate for loss of braking torque.

LAUNCH CONTROL

Optimises gear selection and EBS functions for manoeuvring at low speeds. Among other things, ensures that the Hill Start Aid function is only activated on uphill gradients.

I-ROLL

Automatic engagement and disengagement of a freewheel function for the purpose of reducing fuel consumption. I-Roll is used when neither engine power nor engine braking is needed, for instance on flat roads.

SMART CRUISE CONTROL

Interacts with the vehicle's Brake Cruise and ensures that the auxiliary brakes are not activated unnecessarily. The free-wheel function can thus be utilised to an even greater extent.

I-SEE

A smart I-Shift software that can store topography data and uses this information to optimise driving when the truck travels the same stretch of road a second time. I-See can be used for saving fuel and improved driving comfort. When ordering I-See the cruise control I-Cruise is also included. I-Cruise can also be ordered separately.

HEAVY DUTY GCW CONTROL

Optimises gear selection for high gross combination weights, 85–180 tonnes, for certain engine/gearbox combinations.

ADDITIONAL OPTIONS **ENHANCED PTO FUNCTIONS**

Several functions that make power take-off use easier.

 ENHANCED GEAR SELECTION**ADJUSTMENT INCLUDING KICK-DOWN**

Makes it possible to adjust gear selection via the gear lever's buttons during start and when driving in automatic mode. The kick-down function selects the right gear for maximum acceleration.

 ENHANCED PERFORMANCE - BAD ROADS

Several functions that adjust gearchanging and assist starting and driving on poor road conditions and hilly terrain.



2 DRIVELINE

MANUAL GEARBOXES

14-speed splitter and range manual gearbox. Cable operation – with separate cables for longitudinal and lateral movements – results in short and distinct gear settings. Patented synchromesh with servo function means low gearchanging forces. The gearboxes can be fitted with a compact retarder, power take-off, oil cooler and oil temperature monitoring.

MANUAL GEARBOXES

Type	Top gear	Engine torque (Nm)	GCW approval (tonnes)
<input type="checkbox"/> VT2214B	Direct	2200	100
<input type="checkbox"/> VT02214B	Overdrive	2200	100
<input type="checkbox"/> VT2514B	Direct	2500	100
<input type="checkbox"/> VT02514B	Overdrive	2500	100
<input type="checkbox"/> VT2814B	Direct	2800	100
<input type="checkbox"/> VT02814B	Overdrive	2800	100

CLUTCHES

CS43B-O: 430 mm pull-type single disc-clutch.

CD38B-O: 380 mm pull-type twin disc-clutch.

CD40B-O: 400 mm pull-type twin disc-clutch.

All Volvo's clutches are asbestos free.



REAR AXLES

Type	Axle	Gear	Max torque (Nm)	Max axle/bogie load (tonnes)	GCW approval (tonnes)
Single reduction					
<input type="checkbox"/> RSS1344C	Solo	Hypoid	2600	13	44
<input type="checkbox"/> RSS1356	Solo	Hypoid	2400/2800	13	56/44
<input type="checkbox"/> RSS1360	Solo	Hypoid	3550	13	60
<input type="checkbox"/> RTS2370A	Tandem	Hypoid	3550	23	70
Hub reduction					
<input type="checkbox"/> RSH1370F	Solo	Conical spiral cut	3550	13	70
<input type="checkbox"/> RT2610F	Tandem	Conical spiral cut	3550	26	100
<input type="checkbox"/> RT3210F	Tandem	Conical spiral cut	3550	32	100
<input type="checkbox"/> RTH3312	Tandem	Conical spiral cut	3550	33	120

REAR AXLE RATIOS

RSS1344C	RSS1356	RSS1360	RTS2370A	RSH1370F	RT2610F	RT3210F	RTH3312
2.64:1	2.50:1	2.47:1	2.43:1	3.46:1	3.33:1	3.33:1	3.61:1
2.85:1	2.79:1	2.64:1	2.57:1	3.61:1	3.46:1	3.46:1	3.76:1
3.08:1	3.10:1	2.85:1	2.83:1	3.76:1	3.61:1	3.61:1	4.12:1
3.36:1	3.44:1	3.08:1	3.09:1	4.12:1	3.76:1	3.76:1	4.55:1
3.70:1	3.67:1	3.40:1	3.40:1	4.55:1	3.97:1	3.97:1	5.41:1
		3.67:1	3.78:1	5.41:1	4.12:1	4.12:1	7.21:1
		4.11:1	4.13:1		4.55:1	4.55:1	1:1
			4.50:1		5.41:1	5.41:1	
			5.14:1			7.21:1	
			5.67:1				
			6.17:1				

POWER TAKE-OFFS

There is a wide range of clutch-independent and clutch-dependent power take-offs to drive all sorts of body equipment. **+**

CLUTCH-INDEPENDENT POWER TAKE-OFFS

PTER-DIN

Rear-mounted engine power take-off for direct drive of a hydraulic pump.

PTER1400

Rear-mounted engine power take-off with flange connection for hydraulic pump.

CLUTCH-DEPENDENT POWER TAKE-OFFS

PTR-D/PTR-DM/PTR-DH

Low/medium/high-rev with DIN-connection for direct attachment of a hydraulic pump.

PTRD-F

High-rev with connecting flange attachment for direct-fitted propshaft.

PTRD-D

High-rev with dual drive. DIN connection front and rear for direct attachment of hydraulic pumps.

PTRD-D1

High-rev with dual drive. Connecting flange attachment at the rear and DIN attachment at the front.

PTRD-D2

High-rev with dual drive rear and single drive front. Two connecting flange attachments rear and one DIN attachment at the front.

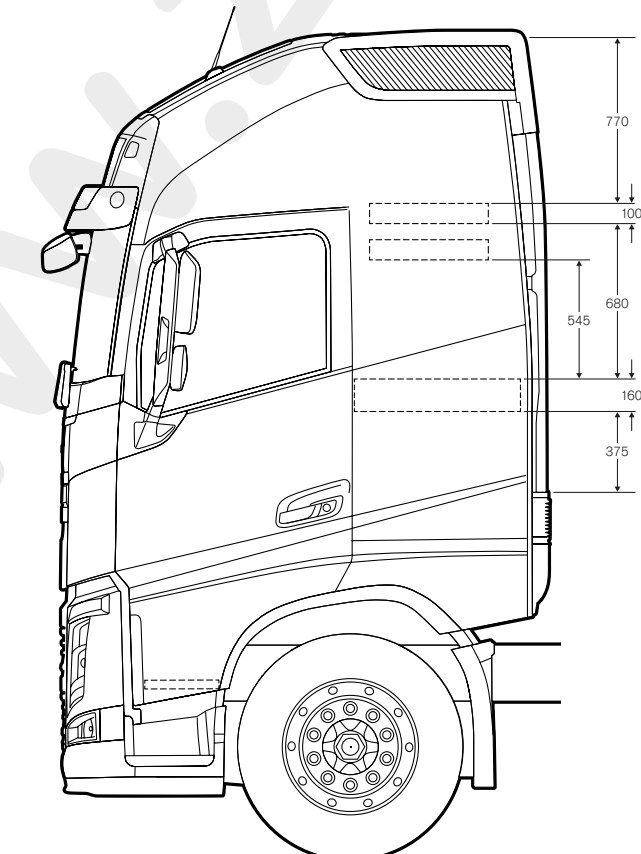
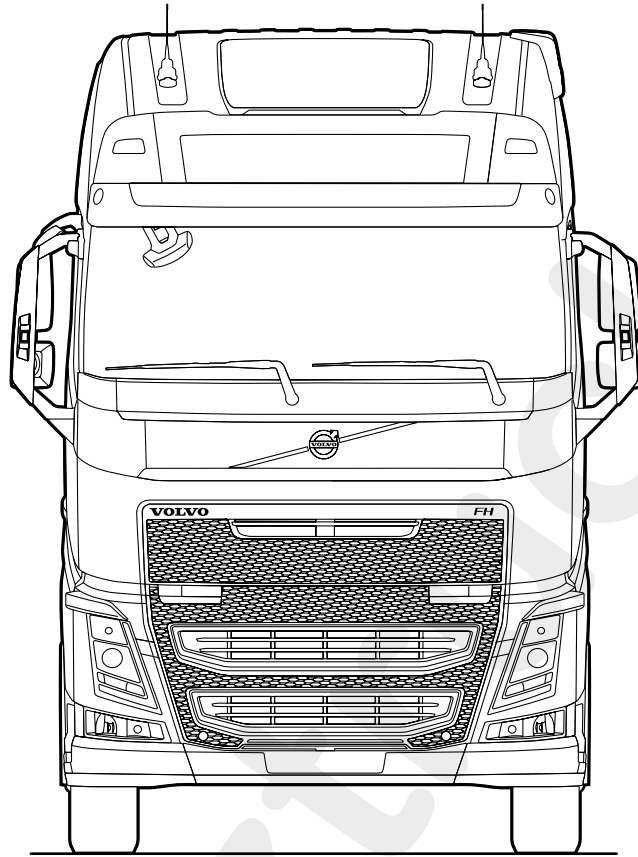



SLEEPER CAB

Sleeper cab (CAB-SLP) with comfortable overnight accommodation for one person. Interior height 171 cm, 162 cm on the engine compartment cover.

GLOBETROTTER CAB

Globetrotter cab (CAB-HSLP) with comfortable overnight accommodation for up to two people. The Globetrotter cab offers extra storage space owing to its vertical structure. Interior height 203 cm, 196 cm on the engine compartment cover.

GLOBETROTTER XL CAB

Globetrotter XL (CAB-XHSL) with comfortable overnight accommodation for up to two people. The Globetrotter XL cab offers extra storage space owing to its added height. Interior height 222 cm, 211 cm on the engine compartment cover.

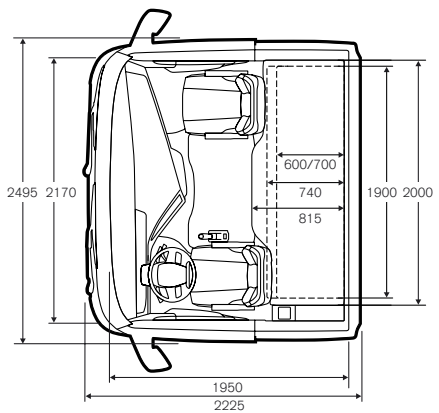
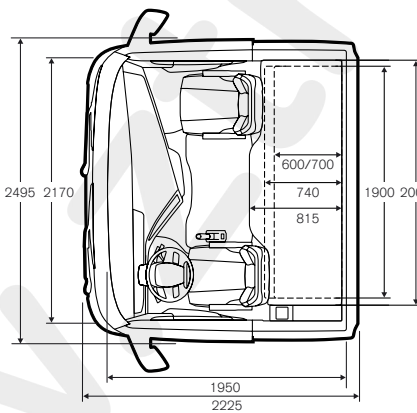
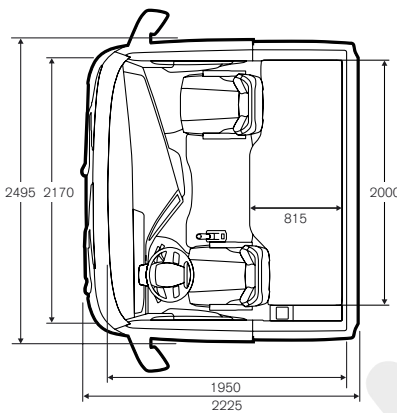
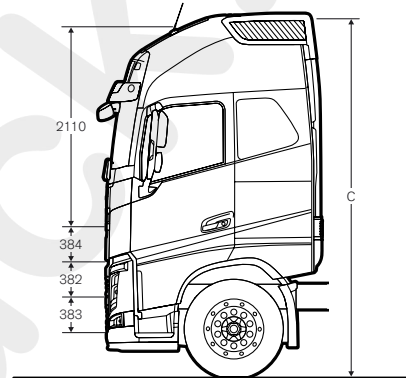
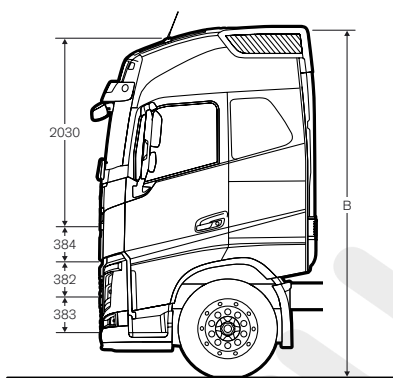
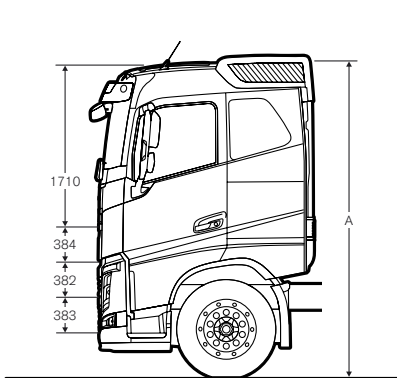

CAB HEIGHT ABOVE THE GROUND

					Height A (mm)	Height B (mm)	Height C (mm)
Tractor	Drive	Chassis height	Suspension	Tyres	Sleeper	Globetrotter	Globetrotter XL
	4x2	High	Leaf/Air	315/80-R22.5	3430	3800	3950
	4x2	High	Leaf/Air	315/80-R22.5	3440	3810	3960
	4x2	Med	Leaf/Air	315/70-R22.5	3350	3720	3870
	4x2	Low	Air/Air	315/60-R22.5	3230	3600	3750
	4x2	Low	Air/Air	315/60-R22.5	3250	3620	3770
	4x2	X-low	Air/Air	295/60-R22.5	3210	3580	3730
	6x2	Med	Leaf/Air	315/70-R22.5	3350	3720	3870
Rigid	Drive	Chassis height	Suspension	Tyres	Sleeper	Globetrotter	Globetrotter XL
	6x2	High	Air/Air	315/80-R22.5	3410	3780	3930
	6x2	Med	Air/Air	315/70-R22.5	3330	3700	3850
	6x2	Low	Air/Air	315/60-R22.5	3230	3600	3750
	6x2	High	Leaf/Leaf	315/80-R22.5	3460	3830	3980
	6x4	High	Leaf/Leaf	315/80-R22.5	3450	3820	3970
	8x4	High	Leaf/Leaf	315/80-R22.5	3480	3850	4000



3 CAB

FOUR-POINT CAB SUSPENSION

Coil springs with dampers all-round, coil springs at front and air suspension at rear, and air suspension all-round.

AIR INTAKES

Air intake positioned on the left side and available in high or low version. Front air intake available as an option.

COLOURS

Available in about 850 variants.

UPHOLSTERY

Volvo FH: Vinyl, textile, soft textile and leather.
Volvo FH16: Textile/Leather and two coloured leather.

All seat trims except vinyl and textile can be ordered with ventilating function.

DRIVER'S SEAT

Three different levels of comfort: Standard, Comfort and Deluxe. All levels can be ordered with optional upholstery. The seat's total adjustment scope fore-aft is 240 mm, and vertically 100 mm. The driver's seat is fitted as standard with a head restraint, adjustable and fold-down backrest, vertical and fore-aft adjustment, adjustable lumbar support and adjustable seat angle.

PASSENGER SEAT

Two different levels of comfort: Standard and Comfort, all levels can be ordered with optional upholstery. All the passenger seats are equipped as standard with head restraints. A rotating passenger seat is available as an option.

BEDS

Lower bed: Bed measuring 70×200 cm, with 81.5 cm wide middle section.

Mattresses: Comfort and Recline with 16 cm pocket springs and excellent comfort. Three options of firmness: Soft, Semi-firm and Firm.

Two options of overlay mattress protector that improves sleeping comfort and facilitates bed-making. Recline with adjustable backrest. Comfort upper bed dimensions 70×190 cm.

INTERIOR STORAGE

Front shelf with four DIN standard recesses and two large storage compartments with roller-doors on the driver's and passenger's sides on high roof cab versions. Under the bed there are two drawers with a total volume of 130 litres. There are two smaller storage compartments under the mattress at the foot (10 l) and head (15 l) of the bed.

Storage compartment at the foot of the bed for a PET bottle.

EXTERIOR STORAGE

On both sides there are large storage compartments that can be opened from either the outside or the inside. Additional unheated storage space of 30 litres is available under the cab on both sides.

SKY WINDOW/ROOF HATCH

The cab is equipped with a fixed sky window or, as option, a roof hatch that can be opened 50 mm. It also serves as an emergency exit.

The roof hatch can be manually or electrically operated.

STEERING WHEEL

Steering wheel in two different sizes – 450 mm or 500 mm in diameter depending on the truck specification. The steering wheel's height can be adjusted by up to 90 mm and the angle can be adjusted by 28 degrees. With neck tilt (option) the steering wheel can be adjusted in vertical position between -5° and +15°, thus increasing the driver's comfort.

CLIMATE SYSTEM

There is a choice of two alternative climate systems to cover all needs.

Air conditioning with manual control (MCC).
Air conditioning with automatic temperature control (ECC/ECC2). This system is also available with sensors for sun intrusion, fog conditions and air quality.

The climate system can also be completed with cab and engine parking heater and I-ParkCool, cab parking cooler.

I-ParkCool produces cool air at standstill and can interact with the cab parking heater to generate a comfortable climate, for example during nights when the temperature often goes from hot to cold in a few hours.

The system checks the battery health to ensure the startability of the truck. It calculates how much cooling power is needed in order to air-condition the cabin. If the batteries aren't fully charged, the system will calculate how much it can be used (without jeopardising the startability). This way, it provides a nice and steady cooling performance during the whole night.

The system is quieter than competing systems in the market, further improving sleeping quality.

The climate system is fully integrated in the vehicle's normal air ventilation system* and hot or cold air respectively is distributed through the ordinary vents comfortably and equally divided. Cab aerodynamics and standing height inside the cab are not affected.

* Except the cab heater (PH-CAB)



DRIVING PACKAGES

	<input type="checkbox"/>	<input type="checkbox"/>	<input type="checkbox"/>	<input type="checkbox"/>	<input type="checkbox"/>
	Driving	Driving+	Driving++	Driving16+	Driving16++
ECC, electronic climate control	•	•			
ECC with quality sensor and carbon filter		◦	•	◦	•
Roof hatch, manual	•			•	
Roof hatch, electrical	◦	•	•	◦	•
Exterior sunvisor, smoke colour	•	•	•	•	•
Armrests, driver seat	•	•			
Armrests, both seats		◦	•		
Heated and electrical mirrors	•	•	•	•	•
Interior sunvisor front, roller blind, electrical		•	•	◦	•
Interior sunvisor side, both sides		◦	•	◦	•
Centre front drawer, low	•	•	•	◦	•
Centre front drawer, high		◦	•	◦	•
Leather armrests	◦	•	•		
Leather steering wheel	◦	•	•		
Leather instep grab handle	◦	•	•		
Adjustable steering wheel with necktilt	◦	•	•	◦	•
Exterior trim level, enhanced		◦	•		
Painting level, complete incl. enhanced exterior trim detail	◦	◦	•		

◦ = option

RESTING PACKAGES

	<input type="checkbox"/>	<input type="checkbox"/>	<input type="checkbox"/>	<input type="checkbox"/>	<input type="checkbox"/>	<input type="checkbox"/>
	Sleeper cab		Globetrotter and Globetrotter XL cab			
	1 bed	1 bed+	1 bed	1 bed+	2 beds	2 beds+
Foldable bunk	•		•		•	
Recline bunk, manually manoeuvred		•		•		•
Recline bunk, electrically manoeuvred		◦		◦		◦
Top bunk, 700 mm wide, foldable					•	•
Top bunk, 700 mm wide, adjustable					◦	◦
Rear upper storage, 245 litres			•	•		
Rear upper storage, 154 litres	•	•			•	•
Bottle holders in driving and living areas	•	•	•	•	•	•
Cab parking heater	•	•	•	•	•	•
Advanced sleeper control panel	•	•	•	•	•	•
Night light and dimmer	•	•	•	•	•	•
Auxiliary shelf, front upper storage			•	•	•	•
Refrigerator, 33 litres		•		•		•
Microwave oven, preparation kit				•		•
Microwave oven				◦		◦
TV, preparation kit				•		•
Table		•		•		•
Relax seat, swivel, tilt		•		•		•

◦ = option



4 EQUIPMENT PACKAGES

AUDIO PACKAGES				
	<input type="checkbox"/>	<input type="checkbox"/>	<input type="checkbox"/>	<input type="checkbox"/>
	Basic	Medium+	Advanced	Advanced Power
Display				
Basic display	•	•		
Large high level display			•	•
Key Audio Functions				
Audio CD	•	•	•	•
CD-R/CD-RW	•	•	•	•
wav/wma/mp3/iTunes		•	•	•
Speed-dependant volume control		•	•	•
Extended mute functions		•	•	•
Radio				
FM/AM antenna	•	•	•	•
FM stations	12	18	18	18
AM stations	6	6	6	6
RDS	•	•	•	•
Connections and interfaces				
Low-level input, 4 channels		•	•	•
3.5 mm stereo line input			•	•
USB connection			•	•
iPod interface			•	•
Bluetooth		•	•	•
Speakers				
Number of speakers	6	6	6	6
Output	4x20W	4x35W	4x35W	8x50W
Subwoofer				•
High-performance tweeters				•
ACTIVE SAFETY PACKAGES				
	<input type="checkbox"/>	<input type="checkbox"/>	<input type="checkbox"/>	<input type="checkbox"/>
			Active Safety	Active Safety+
Basic Electronic Stability Program			•	•
Adaptive Cruise Control + Forward Collision Warning			•	•
ACC brake			○	○
Lane Changing Support			•	•
Driver Alert Support				•
Lane Keeping Support				•
○ = option				
AIRFLOW PACKAGE				
	<input type="checkbox"/>	<input type="checkbox"/>	<input type="checkbox"/>	<input type="checkbox"/>
Cab roof deflector				•
Cab side deflectors				•
Chassis side skirts*				•
Side underrun protection				•
* 4x2 and long wheelbase 6x2 tag axle tractors only.				



PERSONAL PROTECTION PACKAGE

- Alarm
- Alarm with external sensor
- Driver's safe below bed
- Laminated door glass
- Main switch, remote controlled circuit shutdown
- Main switch as for ADR trucks

-
-
-
-
-
-
-

○ = option

VISIBILITY PACKAGES

- Head lamp cleaning
- Static cornering lights
- Rain sensor
- Bi-Xenon headlights
- Dynamic headlights (Bi-Xenon)

- | <input type="checkbox"/> | <input type="checkbox"/> |
|--------------------------|--------------------------|
| Visibility | Visibility+* |
| • | • |
| • | • |
| • | • |
| • | • |
| • | ○ |

○ = option. * Visibility+ is only available with rear leaf suspension.

LONG HAUL FUEL PACKAGES

- Vehicle package**
- I-See, gearbox software including I-Cruise
- Engine idle shutdown
- Power steering pump with variable displacement
- 150A alternator
- Clutchable 2 cylinder 900 cc/min air compressor
- Fuel service package**
- Fuel Advice
- Dynafleet Fuel and Environment
- Driver training: Efficient driving

-
-
-
-
-
-
-
-
-
-
-

TRANSPORT EFFICIENCY PACKAGE

- Dynafleet Driver times
- Dynafleet Messaging
- Dynafleet Positioning
- GPS navigator
- Driver times feedback
- Driver training: Transport Business and Legislation

-
-
-
-
-
-

NEW VOLVO GOLD CONTRACT

- In addition to the existing maintenance and repair programme, the new gold contract also contains:
- New Service Planning
- Features Online
- Uptime Assurance

-
-
-
-



5 ACCESSORIES

HARDWARE	ORDER NO
<input type="checkbox"/> Electric drying cupboard	82280656
<input type="checkbox"/> Exterior water tank (7 litres)	82273017
<input type="checkbox"/> Seat covers	Various options
<input type="checkbox"/> Bull bar	82708130
<input type="checkbox"/> Lower light bar	82708309
<input type="checkbox"/> Upper light bar/Snow plough bar	82708308
<input type="checkbox"/> Dirt deflectors (kit)	21368464
<input type="checkbox"/> Wind deflectors, side window (kit)	21368470
<input type="checkbox"/> Bunk curtains and rail	Various options
<input type="checkbox"/> Waste paper basket	82269739
<input type="checkbox"/> Cradle for mobile phone or iPad	82417710
<input type="checkbox"/> Headlamp protector (right/left)	82366782/82366411
<input type="checkbox"/> Headlamp protector, off-road (kit)	82442563
<input type="checkbox"/> Air horn	8153766
<input type="checkbox"/> Wheel cover, front	82420161 + 82403771
<input type="checkbox"/> Wheel cover, rear	82420162 + 82403771
<input type="checkbox"/> Wheel nut covers	82412116 + 82403771
<input type="checkbox"/> Wheel nut caps, chrome (48.5 mm/54 mm)	21106067/21106069
<input type="checkbox"/> Round spotlamp, white	85104138
<input type="checkbox"/> Round spotlamp, blue	85105501
<input type="checkbox"/> Refrigerator (33 litres) with freeze box	82174077
<input type="checkbox"/> Rubber tray card holder	82421757
<input type="checkbox"/> Coffee maker (requires preparation kit)	84036686

ELECTRONIC/SOFTWARE	REQUIRES
<input type="checkbox"/> SID-High	SID-Bas
<input type="checkbox"/> Exterior vision camera	SID-High
<input type="checkbox"/> Driver Alert Support	Lane Keeping Support
I-Shift software packages	
<input type="checkbox"/> Basic	
<input type="checkbox"/> Distribution & Construction	
<input type="checkbox"/> Long Haul & Fuel Economy	
<input type="checkbox"/> Long Haul & Fuel Economy with I-See (including I-Cruise)	I-Shift + the new TGW
<input type="checkbox"/> Heavy Duty Transport	
<input type="checkbox"/> I-Cruise	
<input type="checkbox"/> Work Remote for ECS	
<input type="checkbox"/> Load indicator	
<input type="checkbox"/> ECS added functions	
<input type="checkbox"/> EBS Medium	EBS Standard
<input type="checkbox"/> ESP (Electronic Stability Program)	EBS (Standard/Medium)
<input type="checkbox"/> EEV (upgrade from Euro 5)	
<input type="checkbox"/> Engine protection	
<input type="checkbox"/> Engine idle shutdown	
<input type="checkbox"/> PTO retrofit/upgrade	
Audio system upgrades	
<input type="checkbox"/> Audio Advanced, including USB, AUX and Bluetooth	
<input type="checkbox"/> Rear speakers	
<input type="checkbox"/> Reversing alarm	
<input type="checkbox"/> Interface for 3rd party fleet management system	
<input type="checkbox"/> Tachograph upgrade	
<input type="checkbox"/> Body Builder Module	
<input type="checkbox"/> Alcolock	
<input type="checkbox"/> Auxiliary lamps (extra spotlights/static cornering lights/fog lights)	

These are only a few of the accessories available for Volvo FH. For a complete list, please talk to your local Volvo dealer.

RSP 2012-gb0003.12.07, English/UK. Printed in Sweden. Some of the equipment shown or mentioned may only be available as options or accessories and may vary from one country to another in accordance with local legislation. Your Volvo dealer will be happy to provide you with more detailed information. Colours may vary somewhat owing to the limitations of the printing process. We reserve the right to alter product specifications without prior notification.



Lower light bar



Alcolock



Exterior water tank



Seat covers